

PAPER • OPEN ACCESS

## Using a heat pump at the complex of energy generation and compressed air production for mining companies

To cite this article: K V Osintsev *et al* 2020 *IOP Conf. Ser.: Earth Environ. Sci.* **579** 012108

View the [article online](#) for updates and enhancements.

# Using a heat pump at the complex of energy generation and compressed air production for mining companies

**K V Osintsev, Y A Perekopnaya and Y S Bolkov**

South Ural State University, 76, Lenina Ave., Chelyabinsk, 454080, Russia

E-mail: osintcevkv@susu.ru

**Abstract.** A further efficiency upgrading of thermal power plants and boiler units at mining companies is linked to increasing the initial parameters of steam. Modern power units can work with an efficiency of 55-58%. However, it is possible to make a review of additional possibilities of heat utilization at a thermal power station. It is quite possible to increase the efficiency by 2-3% more due to the heat regeneration both in this cycle and in the water treatment units. A technology has been developed that combines the ORC and the cycle of compressed air production in a single power engineering system using an improved thermal-transformer, specifically, a refrigeration-heating machine what works in thermal networks of a thermal power station. In addition, from a practical point of view, it is shown that the efficiency of thermal power plant can be improved in comparison with standard schemes. Use of heat pumps beyond heating systems of private houses is becoming increasingly common in centralized heating systems and with feed water of thermal power plants. It significantly reduces the cost of heat and electricity production. Besides, solar collectors can integrate very well into the technological scheme of heating network water at the thermal power plant.

## 1. Introduction

The energy source for industrial and energy boiler units is the fuel, the oxidation of which produces some heat. Oxidation is a chemical reaction what happens at high temperatures. Oxidation is a chemical reaction what happens at high temperatures. The temperature of the burning core reaches 1500-2000 K [1, 2]. During oxidation, a chain of reactions happens, where combustion products are formed such as oxides of carbon, sulfur, nitrogen, and water vapor.

When solid fuel burns, ash is added to them, i.e. unburned metal oxides from coal [3, 4]. The temperature of the flue gases at the exit window of the combustion chamber is 1200-1400 K [5, 6]. This temperature is enough to overheat the steam supplied to the turbines, the scheme for producing heat and electricity by this method is shown in Figure 1 [7, 8]. Next, the gases are cooled at the heating surfaces of the feed water and air, that is, respectively, in economizers and air heaters.

At the exit from the first stage of the air heater, the gas temperature reduces to 380-450 K. With this temperature, the gases move to the purification system, further with temperature decreasing by another 30-40K [9, 10] move to the exhaust fan, and further into the chimney of the thermal power plant. The efficiency of the simplest steam-power cycle at the thermal power plant does not exceed 30% (when it operates on coal) or 37% (when it operates on natural gas).



**2. Analogues. Statement of the problem**

The authors of [1, 2] consider the cycle of microelectric power, including the organic Rankine cycle. In these studies, it was shown that an increase in the efficiency of a power plant is possible only with the use of low-boiling heat carriers. In [3, 4], researchers consider similar problems, but here the solution to the problem of increasing efficiency is considered for capacities of approximately 1 MW. Increasing efficiency of the thermal power plant is possible using gas turbines and waste heat boilers. Thermal power plants produce up to 70 - 80% electricity globally [11, 12].

Nowadays, besides steam turbines, gas turbine plants are used at thermal power plants. In this case, the main equipment is a gas turbine that operates on natural gas. In order to increase efficiency, a process scheme uses a combined electricity and heat production, which are supplied to consumers for industrial needs or for district heating and hot water supply. This is shown in the works [13,14].

To this purpose steam of necessary parameters is output after the corresponding stages of a turbine. At the same time, much less steam passes through the condenser, which allows increasing efficiency. Power plants of this type calls like combined heat and power plants (CHP). Efficiency increase may also be achieved by raising the steam parameters [15,16].

According to expert estimates, raising the steam temperature to 600 °C will increase the efficiency by about 5%, and raising the pressure to 30 MPa will give 3-4% more. It will require a metal with higher strength parameters. It is important to note that for a significant efficiency increase, a binary cycle technological scheme using gas and steam turbines has been developed and is already being used, Figure 2.

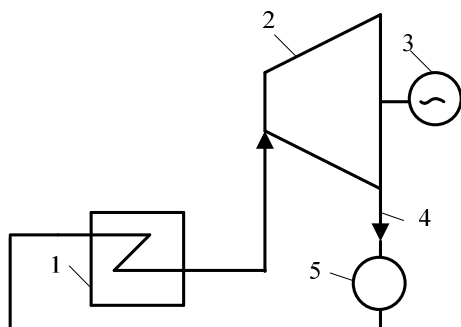

**Figure 1.** The standard cycle work of the steam power plant: 1 – the main steam generator of the power unit, 2 – steam turbine, 3 – electric generator, 4 – exhaust steam, 5 – condenser

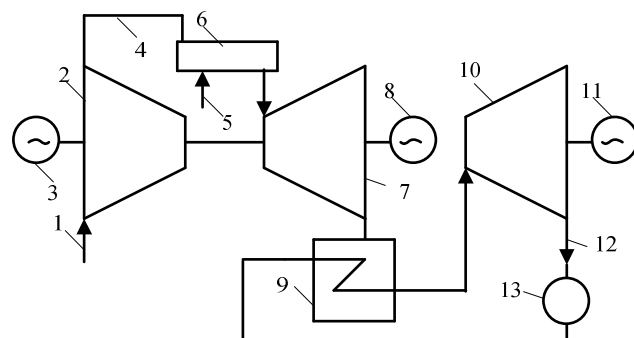

**Figure 2.** Steam-gas cycle of the thermal power station: 1 – air, 2 – compressor, 3 – electric drive, 4 – compressed air, 5 – natural gas, 6 – combustion chamber, 7 – gas turbine, 8 – electric generator, 9 – waste heat boiler, 10 – steam turbine, 11 – electric generator, 12 – exhaust steam, 13 – condenser

After the gas turbine, combustion products move to the waste heat boiler, which is divided in two or three circuits by the heat carrier pressure [17]. The heat carrier is first hot water, and then saturated and overheated steam. Superheated steam moves to the steam turbine for generation an additional electricity amount [18]. The scheme of this cycle is shown in Figure 2.

The efficiency of combined-cycle power units reaches 40-45%. Thermal power station is a set of equipment and devices that convert the energy of fuel into electrical and (in general) thermal energy. Thermal power plants are characterized by great diversity and can be classified according to various criteria. Industrial power plants are power plants that serve specific industrial enterprises or their complex with thermal and electrical energy, such as a chemical plant. Industrial power plants are part of those industrial enterprises that they serve. Their capacity is determined by the needs of industrial enterprises in thermal and electrical energy and, as a rule, it is significantly less than the district thermal power plants.

Often, industrial power plants operate on a common electrical network, but do not obey the dispatcher of the power system. Thermal power plants are divided by the type of fuel used. For condensation power

plants operating on organic fuel, historically the name of thermal power plant was used. It is in this sense that this term will be used below, although steam-gas power plants are also thermal power plants operating on the principle of converting thermal energy into electrical energy. Gaseous, liquid and solid fuels are used as organic fuel for thermal power plants.

Most of the TPPs in Russia, especially in the European part, use natural gas as their primary fuel, and fuel oil as the backup fuel, using the latter because of its high cost only in extreme cases. Such TPPs are called gas-oil. In many regions, mainly in the Asian part of Russia, the main fuel is steam coal - low-calorie coal or waste of high-calorie coal mining. Since before burning, such coal is ground in special mills to a pulverized state, such TPPs are called pulverized coal plants. By the type of heat and power plants used at TPPs to convert thermal energy into mechanical energy of rotation of the rotors of turbine units, there are steam turbine, gas turbine and steam-gas power plants.

The basis of steam turbine power plants are steam turbine plants, which use the most complex, most powerful and extremely advanced energy machine - steam turbine to convert thermal energy into mechanical energy. Steam turbine plants that have condensing turbines as a drive for electric generators and that do not use heat from the exhaust steam to supply external consumers with thermal energy are called condensing power plants. Steam turbine plants equipped with heat-generating turbines and delivering heat to the exhaust steam to industrial or household consumers are called combined heat and power plants.

### **3. Results and discussion**

Nowadays, there are organic Rankine cycles (ORC) known, which increase the efficiency of thermal power plants. There are also complexes for obtaining compressed air. A feature of the proposed technology is the combination of the ORC and the cycle of compressed air production in a single power engineering system using an improved thermal-transformer, specifically, a refrigeration-heating machine what works on thermal networks of a thermal power station. In this paper, for the first time, a scheme of a thermal power plant is presented, which combines the processes of generating heat and electricity, as well as the process of producing compressed carbon dioxide. It should be noted that in this scheme low potential heat is used when the heat pump is operating.

Let us consider the working principle of the first element - the heat pump. Heat pumps use beyond the heating systems of private houses is becoming more common in the heating systems of centralized hot water at thermal power plants, since it significantly reduces the production cost of both heat and electricity. Let us consider the working principle of the second element - the solar collector. Solar energy is absorbed and converted into heat by coating of vacuum tubes.

Heat transfer is carried out from the heat exchange rod through the sleeve to the tank water. The system package includes pipes, an external boiler, a controller, and thus a stable installation must be ensured. Vacuum tubes can absorb infrared rays, so the collector can work on cloudy days. The solar radiation amount moving to the vacuum collector is not subject to change due to the shape of the tubes, and therefore compared to a flat collector, the vacuum absorbs more radiation. The Sun's rays fall to the surface at a right angle, thereby reducing the reflection to a minimum. The collector tubes are arranged in parallel, and the inclination angle of the tubes depends on the location latitude of the installed heating system. This design may have connecting outlets on the side and rear, in order to allow several collectors to be installed closely, and to form a single structural system of a large area.

Lateral connection is used if it is necessary to install structures in a row, as well as to reduce the pressure drop. The advantage of this collector type is that the tubes follow the movement of the Sun throughout the day, and if necessary, you can reduce the area by removing or adding the tubes, while replacement of individual tubes does not require the system to shutdown.

Vacuum solar collectors serve the house well with hot water, they are effective for provide heat using, and can be used at ventilation systems of buildings and structures for the different purposes. In addition, such solar collectors can fit well into the process scheme of heating network water in a thermal power plant.

#### 4. Conclusion

Thus, the following scientific and practical results were identified and disclosed in the article. A technology has been developed that combines the ORC and the cycle of compressed air production at the single energy industry complex using the improved thermal transformer, namely, the refrigeration-heating machine that works in thermal networks of the thermal power station. In addition, from the practical point of view, it is shown that the efficiency of standard thermal power plants can be improved. The organic Rankine cycle is most suitable for operation in low and medium power ranges, usually a few MW maximum, since small power stations cannot afford a local operator. In addition, the cycle has a relatively simple structure and it does not require components that are difficult to manufacture. Therefore, it is more adapted to decentralized power generation. The steam cycle is more suitable for high power ranges.

#### Acknowledgments

The work was supported by Act 211 Government of the Russian Federation, contract №02.A03.21.0011.

#### References

- [1] Mikielewicz D and Jakubowska B 2018 Performance of the domestic micro ORC equipped with the shell-and-tube condenser with minichannels *Energy* **157** 853-861
- [2] Fan J, Liu Q and Song F 2018 A new corresponding-states model for estimating the vaporization heat of working fluids used in Organic Rankine Cycle *Fluid Phase Equilibria* **469** 40-47
- [3] Shi L, Shu G, Tian H and Deng S 2018 A review of modified Organic Rankine cycles (ORCs) for internal combustion engine waste heat recovery (ICE-WHR) *Renewable and Sustainable Energy Reviews* **92** 95-110
- [4] Ma W, Liu T, Min R and Li M 2018 Effects of physical and chemical properties of working fluids on thermodynamic performances of medium-low temperature organic Rankine cycles (ORCs) *Energy Conversion and Management* **171** 742-749
- [5] Zhu Y, Li W, Sun G and Li H 2018 Thermo-economic analysis based on objective functions of an organic Rankine cycle for waste heat recovery from marine diesel engine *Energy* **158** 343-356
- [6] Bo Z, Sang Z, Lu X and Weng Y 2018 Effects of different working fluids on the performance of a radial turbine in an organic Rankine cycle power system *Journal of Mechanical Science and Technology* **32(9)** 4503-4515
- [7] LARGERON C, KRINNER G, CIAIS P and BRUTEL-VUILMET C 2018 Implementing northern peatlands in a global land surface model: Description and evaluation in the ORCHIDEE high-latitude version model (ORC-HL-PEAT) *Geoscientific Model Development* **11(8)** 3279-3297
- [8] Liu L, Zhu T, Gao N and Gan Z 2018 A Review of Modeling Approaches and Tools for the Off-design Simulation of Organic Rankine Cycle *Journal of Thermal Science* **27(4)** 305-320
- [9] Osintsev K V, Prikhodko I S and Zavyalova M I 2018 Methods for improving energy efficiency of air handling unit using factor analysis of data *IOP Conference Series: Earth and Environmental Science* **194** 052019
- [10] Aidarova S, Bekturganova N, Kerimkulova M and Sharipova A 2014 The influence of surfactants to the stability of coal water suspension *Periodica Polytechnica Chemical Engineering* **58** 21-26
- [11] Osintsev K, Zhirgalova T and Khasanova A 2017 Operation principles of gas turbine generator *Industrial Engineering, Applications and Manufacturing* **121** 17285369 1-4
- [12] Han D, Hao L and Yang J 2019 Experimental investigations on vibration characteristics for bearing-rotor system of micro gas turbine *Mechanisms and Machine Science* **63** 343-356
- [13] Emami M, Shahbazian H and Sunden B 2019 Effect of operational parameters on combustion and emissions in an industrial gas turbine combustor *Journal of Energy Resources Technology, Transactions of the ASME* **141(1)** 012202 1-5

- [14] Villagran-Villegas L, Hernandez-Gomez L, Patiño-Ortiz M, Cuellar-Orozco M and Toledo-Velazquez M 2019 Analysis of the wear damage on offshore gas turbine blades *Advanced Structured Materials* **92** 221-236
- [15] Saha A, Saikia L, Rajbongshi R, Saha D and Tasnin W 2019 AGC of thermal-split shaft gas turbine system integrating IPFC and ultra-capacitor *Advances in Intelligent Systems and Computing* **757** 105-115
- [16] Thulukkanam K 2013 *Heat Exchanger Design Handbook*, 2nd ed (CRC Press) p 1245
- [17] Danilov O L, Garyaev A B, Yakovlev I V et al 2011 *Energy Saving in Heat Power Engineering and Heat Technologies* (Moscow: MPEI Publishing house) p 424
- [18] Thermal calculation of boilers (Standard method) 1998 (Saint-Petersburg: NPO CKTI) p 256